

## **Systems methodologies in Vitae Systems of Systems**

Keith W. HIPEL\*  
D. Marc KILGOUR\*\*,\*\*  
Liping FANG\*,\*\*\*

\*Conflict Analysis Group

Department of Systems Design Engineering, University of Waterloo, Waterloo, Ontario, N2L 3G1, Canada

\*\*Department of Mathematics, Wilfrid Laurier University, Waterloo, Ontario, N2L 3C5, Canada

\*\*\*Department of Mechanical and Industrial Engineering, Ryerson University, 350 Victoria Street, Toronto, Ontario, M5B 2K3, Canada

(Received December 17, 2010 Accepted March 15, 2011)

### **ABSTRACT**

Systems methodologies constitute an implementation science to address complex environmental problems from a Vitae Systems of Systems perspective. The aim of Implementation Science is to obtain sustainable, fair and responsible solutions that satisfy as much as possible the value systems of stakeholders while upholding the Vitae principles of survivability, viability and conviviality. To represent the environmental and other societal problems under investigation, the insightful concept of a system of systems is adopted. For example, the Vitae viewpoint on solutions to global warming problems at the regional, national or international level is captured in the interactions of societal systems, such as industrial and service systems, with atmospheric, oceanic and land systems. To tackle the strategic aspects of complex systems of systems problems, there is a rich variety of systems engineering decision tools that can handle multiple stakeholders with multiple objectives; these tools are explained and compared according to their inherent capabilities.

To demonstrate how systems tools can implement a Vitae Systems of Systems philosophy, three different techniques are applied to complex large-scale environmental and water resources management problems. The Graph Model for Conflict Resolution is used to address the large-scale environmental problem that arose over a massive irrigation project proposed for the US state of North Dakota – the infamous Garrison Diversion Unit. Next, a large-scale optimization model, integrating concepts from hydrology, economics and cooperative game theory, is employed to identify fair and feasible allocations of water resources among users in the South Saskatchewan River Basin located in southern Alberta, Canada. Finally, Multiple Criteria Decision Analysis techniques are used to assess different strategies to satisfy future water demand from multiple stakeholders within the Regional Municipality of Waterloo situated in southern Ontario, Canada.

**Keyword:** environmental systems management; graph model for conflict resolution; implementation science; multiple criteria decision analysis; resource allocation; risk assessment; systems engineering; system of systems; vitae systems; water resources management.

## 1 Systems thinking for Vitae Systems of Systems

Systems of systems (SoS), involving multiple participants with multiple objectives, can be classified into the four main types, environmental, societal, intelligent, and integrated, shown in Figure 1 (Hipel and Fang, 2005; Hipel *et al.*, 2007). The set of all natural systems of systems, within which the other three types can be found, is referred to as environmental systems of systems, and includes hydrological, atmospheric, and ecological systems of systems. The wide range of activities executed by human beings for achieving objectives of individuals and groups constitute societal systems of systems, such as economical, political, infrastructure, and urban systems of systems. For achieving human objectives, intelligent systems of systems, like robotic and mechatronic systems of systems, are designed, implemented, and maintained by humans and organizations within societal systems of systems. Combinations of societal and intelligent systems of systems form integrated systems, such as humans and software agents bidding for products on eBay through the Internet.

A number of overlapping definitions for a system of systems have been proposed. For example, Sage and Biemer (2007) define a system of systems as “a large-scale, complex system, involving a combination of technologies, humans, and organizations, and consisting of components which are systems themselves, achieving a unique end-state by providing synergistic capability from its component systems”. Based upon earlier research by Maier (1998), Sage and Cuppan (2001), and others, Sage and Biemer (2007) put forward the following key characteristics that a system of systems should possess:

- operational independence of the individual system,
- managerial independence of the individual system,
- geographical distribution,
- emergent behavior,
- evolutionary development,
- self-organization, and
- adaptation.

Additionally, another important characteristic of a system of systems is the presence of multiple participants along with each participant’s value systems as suggested by Hipel and Fang (2005) and Hipel *et al.* (2007, 2008b, 2009, 2010).

Okada (2002) proposed the Vitae System, a con-

ceptual framework for integrated disaster risk management, as an organizing framework to minimize the vulnerability to disasters of a complex social system. The three Vitae System principles are

- **Survivability:** Aim for resilience, defined as the ability to withstand shocks with (1) the least possible probability of damage or (2) the least severe damage. *Make sure you survive in the short term.*
- **Viability:** Promote good health and provide a range of useful and fulfilling activities. *Encourage each individual to be resourceful and to lead a full and healthy life.*
- **Conviviality:** Emphasize communication and cooperation within a community and among communities. *Aim for positive, reinforcing group interactions.*

By implementing these three principles, a community has the best chance of minimizing the impact of disasters, or of avoiding them altogether.

The aim of this paper is to show how the Vitae System can be incorporated into a systems of systems paradigm. This integration is particularly beneficial because it brings a broad range of proven tools and techniques to the practical implementation of the Vitae System. Figure 2 presents a Vitae Systems of Systems framework. This structure therefore enables practitioners, planners, and decision-makers to implement policies and practices for risk management and sustainable development. These policies and practices must not only be technically, environmentally, financially, and economically feasible, but also be socially and politically viable. Thus, SoS decision methodologies can constitute an Implementation Science, under

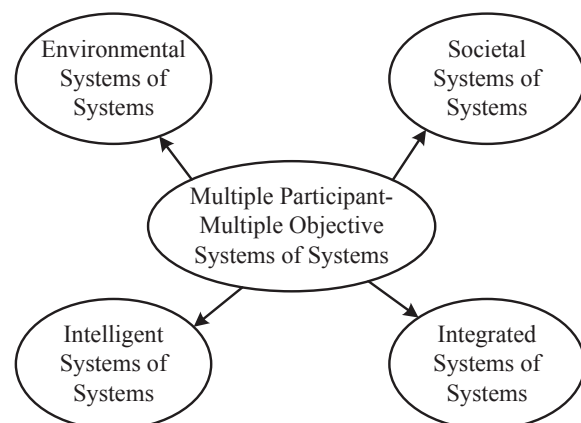

**Figure 1** Types of multiple participant-multiple objective systems of systems

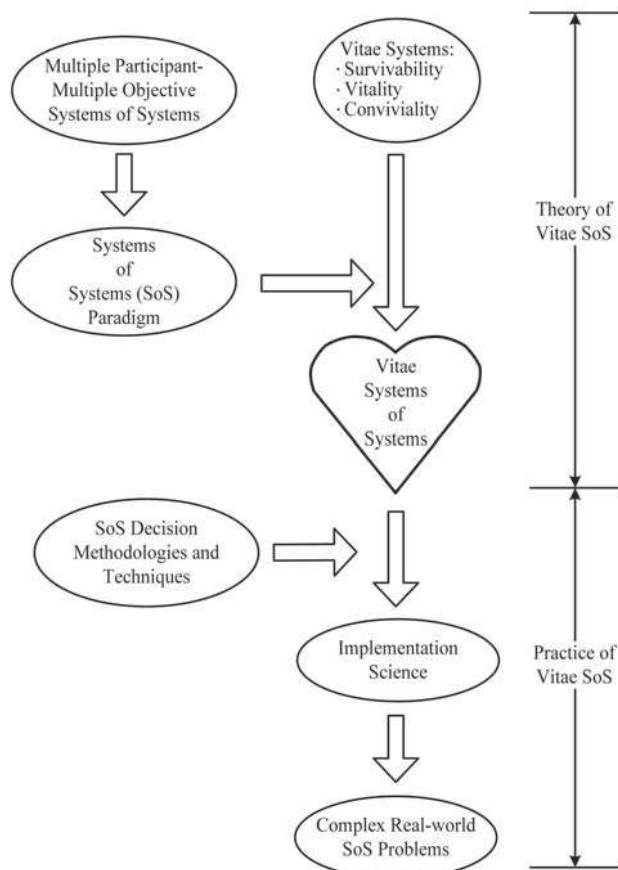

Figure 2 Vitae Systems of Systems

the umbrella of the Vitae Systems of Systems philosophy. Some of these SoS decision methodologies are described in the next section, and illustrated using three specific examples in Section 3: strategic analysis of an international environmental conflict (Section 3.1), fair water allocation among competing uses in a large-scale river basin (Section 3.2), and selection of a regional water supply system according to a range of criteria (Section 3.3).

## 2 Systems tools for Vitae Systems of Systems

Systems tools and methodologies for formally modeling and analyzing decision making processes that could arise in Vitae Systems of Systems have been developed within a range of systems-related disciplines, such as Operational Research, Systems Engineering, Industrial Engineering and Project Management. All of these disciplines were launched just before, during or after World War II. For example, Operational or Operations Research (OR) was initiated in July 1938 when the British High Command ordered that research be executed with respect to the

operational aspects of radar systems (Blackett, 1962; Waddington, 1973; Hipel *et al.*, 2008a). Although its origins can be traced back to WW II, Systems Engineering (Sage, 1992; Sage and Rouse, 2008) became firmly established as a discipline at NASA (National Aeronautics and Space Administration) in the US in the 1960s and 1970s. In fact, these “systems science” fields provide a broad range of approaches to decision making which constitute a valuable component of Implementation Science because they have been operationalized for actual application to complex real-world problems.

A systems thinking approach to decision making is both an art and a craft. The art consists of a general approach to solve a given complex decision making problem in which one must take into account the technical, environmental, financial, economic and political aspects of the challenging Vitae Systems of Systems problems being investigated. The craft component refers to the rich variety of mathematically-based decision tools which have been specifically designed for solving real problems in the design, management, maintenance and operation of systems of systems. Figure 3 depicts how formal decision making methods can be categorized according to the factors of the number of decision makers (DMs) and the number of objectives. As can be seen, most techniques reflect the viewpoint of one DM having one objective. For instance, linear programming can be employed as an optimization tool by an organization to minimize its costs. Team theory is an example of a technique for modeling a situation in which there are two or more team members, such that each member is pursuing the single objective of winning. Multiple criteria decision analysis (MCDA) methods are designed for finding the more preferred alternative solutions to a problem when the discrete alternatives are evaluated against criteria ranging from cost (a quantitative criterion) to aesthetics (a qualitative criterion) (see books by authors such as Belton and Stewart (2002), Hobbs and Meier (2000), and Hammond *et al.* (1999) for good descriptions of MCDA techniques). The evaluations of the criteria for each alternative reflect the objectives or preferences of the DM. As indicated in the bottom right cell in Figure 3, game theory methods are designed for handling a decision problem in which there are multiple DMs, participants, players or stakeholders, each of whom has multiple objectives.

Finally, as pointed out by authors such as Hatfield and Hipel (2002) and Haimes (2009), risk assessment forms an integral part of strategic decision making involving multiple DMs and objectives. A comprehensive set of risk assessment tools is needed for taking a Vitae System of Systems approach for tackling tough systems problems, such as preserving resilience in societal systems, which constitutes a systems property that is of great import in proactively planning for effective responses to natural disasters. For instance, reliable and adaptable systems plans were in place to permit the Japanese people to respond as effectively as possible to the massive earthquake and accompanying devastating tsunami that occurred suddenly on March 11, 2011 in northeast Japan near Sendai.

Multiple participant-multiple objective decision making is in reality the most general type of decision making and it is certainly an inherent characteristic of Vitae Systems of Systems. An informative way in which to classify a game theoretic method is according to the DMs' type of preference information. A given DM's preferences reflect his or her beliefs, value systems, priorities and objectives. Therefore, to

calibrate a conflict model, one must elicit each DM's preferences over the feasible outcomes or states in a particular conflict. The methods listed in the left column in Figure 4 are usually categorized as being non-quantitative approaches, since they only assume relative preference information. Hence, it is not necessary to know exactly the degree to which one prefers one state over another. Moreover, Metagame Analysis (Howard, 1971), Drama Theory (Howard, 1999; Bryant, 2003), Conflict Analysis (Fraser and Hipel, 1979, 1984), and the Graph Model for Conflict Resolution (Kilgour *et al.*, 1987; Fang *et al.*, 1993) can handle both transitive and intransitive preferences. Techniques falling within the right branch in Figure 4 generally require cardinal preference information expressed by von Neumann and Morgenstern (1953) utility functions. Accordingly, these techniques are usually labeled as being quantitative. One should keep in mind that all of the procedures given in both the left and right parts of Figure 4 constitute formal mathematical models.

Significant research advances in the development of decision techniques that concentrate on multiple

		OBJECTIVES	
		One	Two or More
DECISION MAKERS	One	Most Models	Multiple Criteria Decision Analysis
	Two or More	Team Theory	Game Theory

Figure 3 Classification of decision making methods

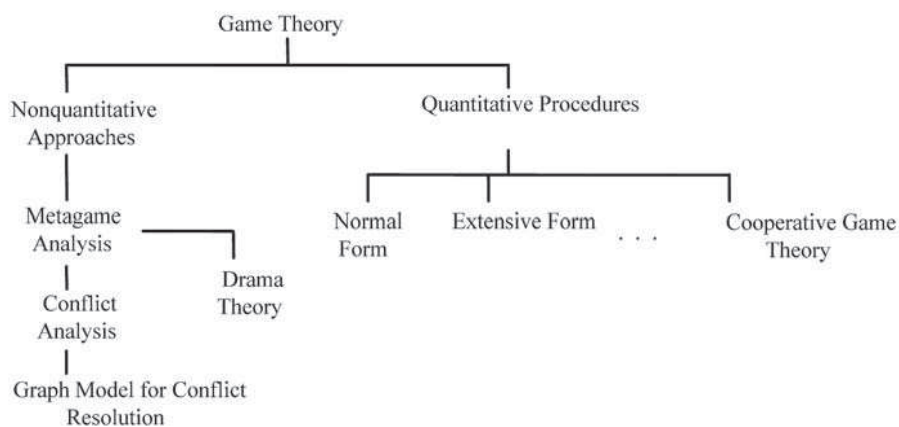

Figure 4 Genealogy of formal conflict models

stakeholders having multiple objectives have been made, in conjunction with insightful water resources, environmental management and other kinds of applications, by members of the Conflict Analysis Group at the University of Waterloo. For instance, important methodological extensions to the Graph Model for Conflict Resolution (Kilgour *et al.*, 1987; Fang *et al.*, 1993; Hipel *et al.*, 1993; Hipel, 2009a,b) include its capability to model coalitions (Kilgour *et al.*, 2001; Inohara and Hipel, 2008a,b), uncertain preference (Li *et al.*, 2004a, 2005a), strength of preference (Hamouda *et al.*, 2004, 2006; Xu *et al.*, 2009b), fuzzy preferences (Al-Mutairi *et al.*, 2008; Hipel *et al.*, 2011), emotions (Obeidi *et al.*, 2005, 2006, 2009a,b), attitudes (Inohara *et al.*, 2007; Walker *et al.*, 2009), policies (Zeng *et al.*, 2007), large conflicts (Xu *et al.*, 2009a,c) and the evolution of a conflict to a final outcome (Li *et al.*, 2004b, 2005a,b). To permit the Graph Model methodology to be applied in practice, a flexible decision support system has been constructed (Fang *et al.*, 2003a,b; Hipel *et al.*, 1997, 2001).

Other contributions to the creation, refinement and application of decision-making techniques include initiatives in multiple criteria decision analysis (MCDA) methods (such as Rajabi *et al.* (1998, 1999) and Chen *et al.* (2006, 2007, 2008)), enforcement techniques for environmental regulations (Kilgour *et al.*, 1992; Hipel and Fang, 1994; Fang *et al.*, 1997), fair resource allocation (Wang *et al.*, 2007a,b, 2008a,b) and decision making under uncertainty (see, for example, Hipel and Ben-Haim (1999) and Hipel and McLeod (1994)). Professor Norio Okada and his research team in Japan, first at Tottori University and later within the Disaster Prevention Research Institute at Kyoto University, have completed high quality research on challenging topics such as regional planning, environmental and water resources management, allocation of costs and benefits, mitigation of natural disasters and risk assessment. Collaborative research projects between Canadian and Japanese researchers produced publications on subjects including conflicts with misperceptions (Okada *et al.*, 1985), conflict analysis (Okada *et al.*, 1988), regulation of pollutant discharges into lakes (Kilgour *et al.*, 1988), compliance to environmental regulations (Fukuyama *et al.*, 1994, 2000) and participatory infrastructure management (Okada *et al.*, 2006).

### 3 Systems practice

The overall objective of this section is to demonstrate how various systems tools in Figure 4 can be employed in an Implementation Science fashion for addressing complex Vitae Systems of Systems problems. In particular, the Graph Model for Conflict Resolution (given in the left branch of Figure 4), cooperative game theory procedures (right branch in Figure 4) in combination with other appropriate methods, and MCDA techniques (top right cell in Figure 3) are applied to practical realworld problems in environmental conflict resolution, fair allocation of water among users in a river basin, and selection of future reliable water supplies in Sections 3.1 to 3.3, respectively.

The three upcoming applications deal with examples of effectively handling strategic problems which well-functioning societies must address in order to have secure and robust societal systems of systems that interact in responsible ways among and within themselves as well as their supporting environmental system of systems. Having prosperous, fair, and accountable societies means that these societies are in a much stronger and more stable position to be able to act in a proactive, integrative and adaptive fashion to crises, such as natural disasters, from a Vitae System of Systems perspective. Hence, when a disaster does strike, such as the March 2011 Sendai earthquake and accompanying tsunami, lives can be saved, property damage minimized and recovery time kept to a reasonable time period when rebuilding private and public property and infrastructure in order to restore system resilience and other key system characteristics. This kind of Vitae System of Systems philosophy can only grow in importance as increasingly complex societal, technological and natural systems interact in largely unknown ways to produce emergent behaviour, like irreversible climate changes and serious food crises (Hipel *et al.*, 2010), which societies will ultimately have to confront. Now is clearly the time to positively change the attitudes of decision makers in government, industry and non-governmental organizations towards more responsible and realistic ways to govern via systems thinking.

#### 3.1 Conflict resolution in an international environmental conflict

Conflict is an innate characteristic of Vitae Sys-

tems of Systems as people and organizations compete and cooperate within societal and technological systems of systems (Hipel and Fang, 2005; Hipel *et al.*, 2007, 2008b, 2009, 2010). Accordingly, conflict resolution methodologies constitute a key type of Implementation Science for fairly resolving disputes in an attempt to reach win/win settlements among disputants. Consider, now how the Graph Model for Conflict Resolution can be employed for systematically investigating the strategic aspects of a complex international environmental controversy.

The Garrison Diversion Unit (GDU) is a partially constructed multipurpose water resources project in the United States of America (US) that involves the transfer of water from the Missouri River Basin to planned irrigation areas in central and eastern North Dakota, most of which are located within the Hudson Bay Drainage Basin. Because the resulting runoff from the planned irrigated fields would flow via the Red and Souris Rivers into the Canadian province of Manitoba, Canada could become seriously polluted. In particular, adverse environmental effects from the GDU include high pollution levels of the irrigation waters, increased chances of flooding of the Souris River, and the possibility of catastrophic environmental damage caused by foreign biota from the Missouri River Basin destroying indigenous biota such as certain fish species in the Hudson Bay Drainage Basin. Previously, the GDU dispute was formally studied using metagame analysis (Hipel and Fraser, 1980), conflict analysis (Fraser and Hipel, 1984, Ch.

2) and the Graph Model for Conflict Resolution (Fang *et al.*, 1993, Ch. 6). Here, the decision support systems GMCR II is employed to study the conflict as it existed in April 1976. The Graph Model for Conflict Resolution has also been used to model the conflict as it existed in early December 1984, just before a final resolution was reached (Fang *et al.*, 1993, Section 6.6).

Figure 5 lists the DMs and the options under each DM's control for the GDU conflict and with the status quo state existing in April 1976, the point in time for which the modeling and analysis is done. As can be seen, the dispute is modeled as a conflict among four DMs: US Support (for the project), US Opposition (a group composed mainly of environmentalists), Canadian Opposition (mainly the governments of Manitoba and Canada), and the IJC (International Joint Commission), the boundary waters advisory council, with equal representation from Canada and the US, which had recently been requested by the US and Canada to carry out a study in order to make recommendations to both governments on how to handle the problem. The status quo state, consisting of a column of Ys and Ns, is the situation existing at the start of the dispute in April 1976. When defining a state using the option notation, the DM controlling a given option decides whether or not to choose it: a "Y" means "yes", while an "N" indicates "no", and the option is not taken. To form the status quo state in Figure 5, which is written horizontally in text as (YNN N N NNNN), the US Support, US Opposition, Canadian Opposition, and the IJC have chosen the strategies (YNN), (N), (N), and (NNNN), respectively.

Decision Makers and Options	Status Quo State
<b>US Support</b>	
1. Full: Proceed to complete full GDU	Y
2. Reduced: Proceed to complete GDU modified to reduce Canadian impacts	N
3. Appease: Proceed to complete GDU modified to appease US environmentalists	N
<b>US Opposition</b>	
4. Legal: Legal action based on environmental legislation	N
<b>Canadian Opposition</b>	
5. Treaty: Legal action based on the Boundary Waters Treaty of 1909	N
<b>International Joint Commission (IJC)</b>	
6. Full: Support completion of full GDU	N
7. Reduced: Support completion of GDU modified to reduce Canadian impacts	N
8. Lonetree: Support suspension of the GDU except for the Lonetree Reservoir	N
9. Suspend: Support complete suspension of the GDU	N

Figure 5 Decision makers and options for the GDU conflict as of 1976

Besides determining the DMs, each DM's options and the possible feasible states, one must also ascertain the relative preferences among the states for each DM before carrying out an indepth stability analysis. In general, a state is stable for a given DM according to a particular solution concept describing human behaviour under conflict, if it is not advantageous for the DM to move from that state. A state which is stable for all DMs with respect to a specific solution concept is called an equilibrium. Based upon the results of an exhaustive stability analysis, Figure 6 portrays how the conflict evolved from status quo state 1, through the transitional states 26 and 28, to the equilibrium state 34, which actually took place in 1976. The arrows in Figure 6 indicate which option selections a DM changes in order to cause the conflict to move from one state to another. Specifically, the IJC unilaterally causes the conflict to move from state 1 to state 26 by changing its strategy selection from not making a recommendation (strategy NNNN) to recommending the Lonetree Reservoir option (strategy NNYN), which is referred to as an allowable state transition. The US Support then moves the conflict from state 26 to 28 by proceeding to construct a modified GDU project to appease the US Opposition. In response, the Canadian Opposition threatens to go to court under the Boundary Waters Treaty of 1909, and hence causes the conflict to progress from state 28 to 34. Because state 34 is a strong equilibrium, as indicated in Figure 6, no DM has an incentive to unilaterally move from it. Accordingly, this was the equilibrium reached in 1976.

**3.2 Fairness and cooperation for water allocation in a large-scale river basin**

Fair allocation of resources within the multiple participant decision making context is crucial for the implementation of Vitae Systems of Systems in society. Consider the problem of equitably allocating water among the competing users or stakeholders over an entire river basin. Because a unit of water can produce different economic benefits for different users, water allocations based on water rights alone does not usually produce an economically efficient plan for the whole river basin. On the other hand, particular water users will usually consider economically efficient water allocation plans to be inequitable, and unfair plans are often difficult or impossible to implement. Moreover, allocation plans have implications for sustainability – environmental requirements (stream flow and reservoir storage), water quality constraints, conservation of water, and sharing of water shortages, must also be considered. Predicted radical climate behaviour caused by global warming, such as more extreme droughts and floods, only increases the demand for the utilization of responsible and fair resource allocation techniques to help maintain the principles of Vitae Systems of Systems shown in the top right of Figure 2.

A comprehensive Cooperative Water Allocation Model (CWAM) has been developed to find equitable, efficient and sustainable water allocations among competing users or stakeholders in a river basin (Wang *et al.*, 2007a,b, 2008a,b). The CWAM framework integrates concepts from hydrology, economics and

Decision Makers and Options	Status Quo	Transition	States	Equilibrium
<b>US Support</b>				
1. Full: Proceed to complete full GDU	Y	Y ⇒	N	N
2. Reduced: Proceed to complete GDU modified to reduce Canadian impacts	N	N	N	N
3. Appease: Proceed to complete GDU modified to appease US environmentalists	N	N ⇒	Y	Y
<b>US Opposition</b>				
4. Legal: Legal action based on environmental legislation	N	N	N	N
<b>Canadian Opposition</b>				
5. Treaty: Legal action based on the Boundary Waters Treaty of 1909	N	N	N ⇒	Y
<b>International Joint Commission (IJC)</b>				
6. Full: Support completion of full GDU	N	N	N	N
7. Reduced: Support completion of GDU modified to reduce Canadian impacts	N	N	N	N
8. Lonetree: Support suspension of the GDU except for the Lonetree Reservoir	N ⇒	Y	Y	Y
9. Suspend: Support complete suspension of the GDU	N	N	N	N
<b>State Numbers</b>	<b>1</b>	<b>26</b>	<b>28</b>	<b>34</b>

**Figure 6** Transition from the status quo to the equilibrium state

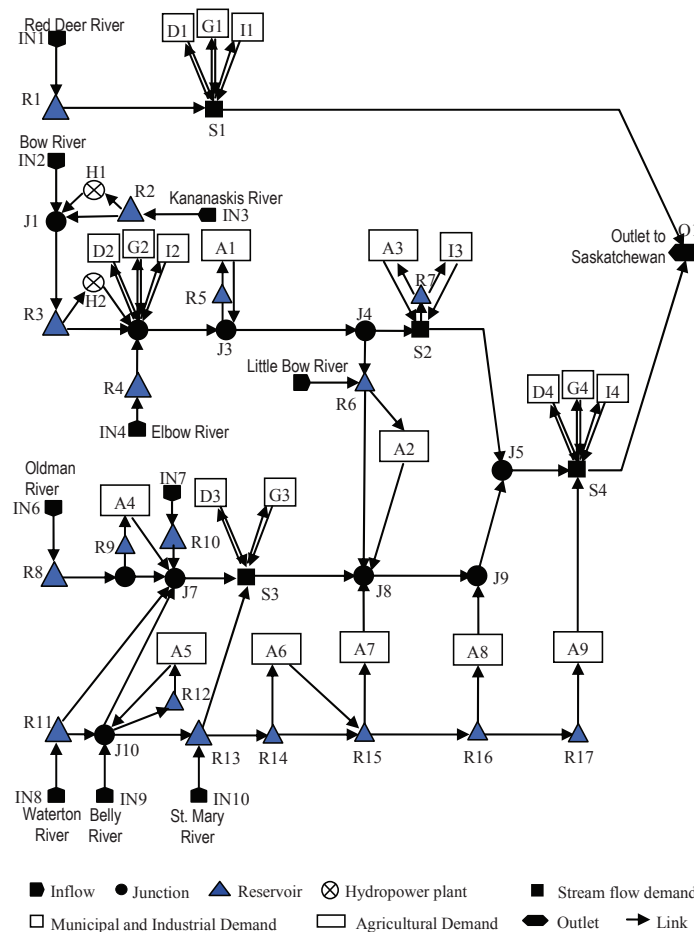

Figure 7 Network of the South Saskatchewan River Basin in southern Alberta

cooperative game theory within an overall large-scale optimization structure. Based on a network representation of the river basin, CWAM allocates water in two steps: (1) initial allocation founded on existing legal rights or agreements; and (2) reallocation of water and net benefits to achieve efficient utilization of water and equitable redistribution of net benefits. The effect of the application of cooperative game-theoretic approaches is to promote cooperation among all users in the river basin. The CWAM methodology has been applied on a large scale to the water allocation problem in the South Saskatchewan River Basin (SSRB) located in the southern part of the Province of Alberta, Canada (Wang *et al.*, 2008a,b). The network representation of SSRB is shown in Figure 7.

### 3.3 Group decision using multiple criteria decision analysis for regional water supply

Water resource development can provide an excellent illustration of the Vitae Systems of Systems philosophy in action. The selection of projects to ensure the future water supply of Waterloo, Ontario,

Canada is a good example. The Regional Municipality of Waterloo, located in the Great Lakes basin, comprises the three cities of Kitchener, Waterloo, and Cambridge, plus adjacent rural municipalities. In 1990, Waterloo decided to develop a Long Term Water Strategy to the year 2041. This extensive study, which took ten years to complete, highlights many issues associated with vitae systems, and illustrates many features that can be expected to arise in the associated decision problems.

In 1990, the Regional Municipality of Waterloo was the largest community in Canada to depend on groundwater for most (over 90%) of its water supply. (Waterloo Regional Council, 2000) The population was almost 500,000, and daily water consumption was about 45 million gallons per day (MGD). Driven mainly by increasing population, water consumption was predicted to increase steadily to 67 MGD in 2041. Almost every year, seasonal droughts led to water restrictions, resulting in the perception that reliability of water supply was a major problem for the Region. Water quality was also a rising issue, as health-related



concerns forced the temporary closure of some wells in Kitchener and Waterloo, which also further exacerbated supply problems. In 1990, it was discovered that a carcinogen, probably of industrial origin, had contaminated the entire aquifer under Elmira (Kilgour *et al.*, 2001); consequent arrangements to supply water to Elmira from elsewhere in the region are still in place. Finally, unusual weather conditions sometimes combined with difficulties in operating dams along the Grand River to produce flooding, the worst instance of which occurred in 1974.

The Region of Waterloo hired Associated Engineering as primary technical consultant for its Long Term Water Strategy project. Meetings of consulting and city engineers, politicians, major water users, and citizens began in 1991. Eventually, the twelve water sources shown in Table 1, along with their likely long-term capacities, were identified as feasible.

The meetings of experts, citizens, and interested parties focused on the discussion of criteria for evaluating the choice of water source. Initially, the primary goals for the project were determined to be:

**Respect and Maintain Tradition** by minimizing changes to existing systems and infrastructure, and by minimizing environmental impacts, negative social impacts, and costs.

**Achieve Water Security** by minimizing the risk of disruption due to poor water quality or sudden decreases in water supply.

**Ensure Water Supply** by reducing or eliminating shortfalls, relative to predicted water needs, insofar as

possible.

Later these goals were refined into seven measurable criteria, as follows: investment cost (INVEST); operating cost (OPER); water quality (QUAL); infrastructure impact (INFRA); environmental impact (ENVIR); risk (RISK); and supply capability (SUPPLY). Two criteria, SUPPLY and QUAL, are positive criteria (increasing values are preferred), while the remainder are negative (decreasing values are preferred).

A preliminary evaluation of the twelve alternatives according to the seven criteria was carried out by consultants to the Region; the results are shown in Table 2. Note that consequence measures (numbers in the body of the Table) are given in natural units as selected by the consultants; no attempt has been made to scale them according to criteria weights.

MCDA techniques are designed to assist a single decision-maker faced with a complex decision problem. The use of such techniques might be questioned in a multiple decision-maker context such as the Waterloo water supply problem. But in this case, the cities of Kitchener, Waterloo, and Cambridge were facing essentially the same problem, and had a long history of cooperation on water-related issues. Moreover, procedures for allocating costs were well-established. Because there was little conflict among the major decision-makers, MCDA techniques are quite appropriate to this problem.

However, the Waterloo water supply problem has two special features that may well characterize decision problems originating in vitae systems, inter-

**Table 1** Feasible water sources and capacities for Waterloo Region

			MGD
Groundwater	GW1	Develop sources in Kitchener and Waterloo	20
	GW2	Develop sources in other areas	20
Aquifer Recharge	AQ1	Recharge and recovery site 1	40
	AQ2	Recharge and recovery site 2	40
Grand River	GR	Increase Grand River extraction	5
Low Flow Augmentation	LF1	West Montrose dam	50
High-Pressure Pipeline	LF2	Low-pressure Georgian Bay pipeline	80
	LF3	Low-pressure Lake Huron pipeline	80
	PL1	Pipeline from Lake Ontario	80
	PL2	Pipeline from Lake Erie	80
	PL3	Pipeline from Lake Huron (Goderich)	80
	PL4	Pipeline from Georgian Bay (Thornbury)	80

dependency and timing. Some of the actions (those sourcing water from the Great Lakes) provided sufficient capacity in themselves to meet long-term water needs, but could not be implemented quickly, necessitating the choice of some other action(s) as a temporary measure. Moreover, actions not sourcing water from the Great Lakes were unlikely to meet needs over the long term, so a Great Lakes source was probably inevitable. In other words, this was not a conventional MCDA problem, since the issue was not to choose an action but to choose a schedule of actions. In particular, actions not sourcing water from the Great Lakes could delay the expensive but inevitable pipeline, and expenditure delayed is money saved. In sum, the timing of choices is at least as important as the choices themselves.

It is important to note that the evaluation of a subset of actions according to a criterion may not bear any simple relation to the evaluations of the individual actions by the same criterion. The whole may be greater than, equal to, or less than the sum of the parts. Rajabi *et al.* (1998, 1999) developed a method of measuring the interdependence of actions which can be applied to this problem. For example, any GW action and any PL action have synergy  $-0.2$  on RISK (because total risk is reduced when there are two different sources) but synergy  $+0.1$  on INFRA (because the required infrastructures are more expensive to build in parallel).

In the MCDA context, Rajabi *et al.* (1999) developed a theory of optimal subset selection, and applied it to a simplified model of the Waterloo Water Supply Problem. Later, Chen *et al.* (2008) showed that the problem can be solved, at least approximately, using screening methods, which do not take direct account of synergies and may therefore be computationally very efficient.

On May 10, 2000, the Waterloo Regional Council

approved a long-term water strategy for Waterloo Region consisting of three alternatives on different construction schedules. Specifically, the plan was to implement AQ1 to a capacity of 5 MGD immediately, with a further 5 MGD of AQ1 in 2007, then GW2 to a level of 3 MGD in 2018, followed by PL2 or PL3 by 2035. Implementation is in progress at this time. Figure 8 shows that the average capacity of the system will remain well ahead of expected needs.

The solution of the Waterloo Water Resources Problem provides an excellent illustration of the vitae principles of survivability, viability and conviviality. The water supply to the region will be adequate for its health and economic development, and the risks to the supply will be minimal. At the same time, environmental and social values have been affirmed, and costs – capital, infrastructure, and operating – have been minimized, ensuring that social resources are available to meet other needs as may be required in the future. Moreover, a community or region’s economic future is constrained by the availability of adequate amounts of clean freshwater. The pollution of an aquifer, such as the one underlying the Town of Elmira in Ontario, Canada (Kilgour *et al.*, 2001), means that the community’s economic vitality and sustainability have been seriously diminished through the loss of its local water supply.

**4 The road ahead**

As exemplified in Section 3 by three large-scale case studies, society is currently facing many challenging problems and, as emphasized by Hipel *et al.* (2007), both expected and unforeseen difficulties will arise in the future. Although the three applications deal with tough systems of systems problems that have occurred or continue to evolve in the North American continent, they reflect general types of situ-

**Table 2** Future water supply for Waterloo Region as an MCDA problem

	GW1	GW2	AQ1	AQ2	GR	LF1	LF2	LF3	PL1	PL2	PL3	PL4
INVEST	100	61	8.6	17	5	112	123.6	111.3	120.4	126	181	222
OPER	4	2.4	5.9	8.8	2	6.2	6.6	6.7	4.2	3.4	2.3	2.5
INFRA	30	30	40	50	30	60	60	60	60	65	60	60
ENVIR	60	60	45	45	40	50	40	90	80	80	80	80
RISK	80	80	50	50	80	60	70	70	30	30	30	30
SUPPLY	20	20	40	40	5	50	80	80	80	80	80	80
QUAL	50	50	70	70	30	60	60	60	70	70	80	70

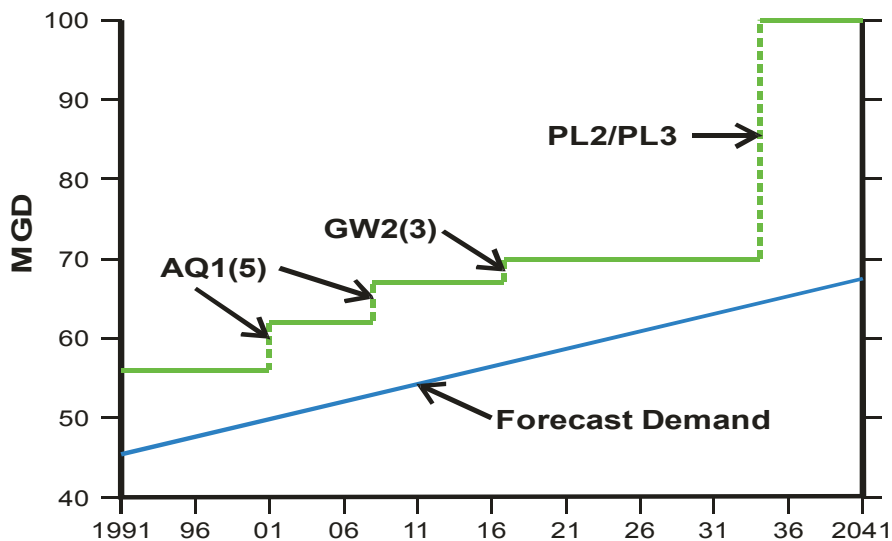

Figure 8 Strategic Plan for future Waterloo water supply (Source: Waterloo Regional Council, 2000)

ations taking place around the globe. For instance, a common feature underlying all three case studies is the decreasing supply of fresh water, along with associated degradation of water quality, in the face of increasing water demand by a rapidly expanding population. Consider water shortages associated with the infamous Aral Sea debacle (see Nandalal and Hipel (2007)) along with associated references) as well as drastic water shortages now taking place in regions such as Australia, North Africa, the Western and Southwestern United States, as well as many parts of China and India. Moreover, most of these problems are interconnected as a result of global warming happening around the world. For instance, global warming is currently causing the glaciers of the Rocky Mountains in Western Canada to retreat which in turn means that summer flows of the Saskatchewan River and its tributaries will certainly decrease in the future since the summer flows are largely generated by these crucial glaciers. Because the rivers flowing from west to east across the provinces of Alberta and Saskatchewan eventually reach Lake Winnipeg in the province of Manitoba, this will cause Lake Winnipeg and other nearby lakes to greatly decrease in size. In fact, Lake Winnipeg has the potential to become the “Aral Sea” of North America. As noted earlier, resilient and secure societies are needed to be able to proactively confront known potential disasters, such as earthquakes and tornadoes, as well as unknown unknowns.

Clearly, systems thinking methodologies, such as those outlined in Section 2 and applied to practical

problems in Section 3, are sorely needed as an Implementation Science for executing, in practice, a Vitae Systems of Systems philosophy discussed in Section 1 and Figure 2. The development of a sound theoretical basis to this new idea of the Vitae Systems of Systems approach will require the talents, attention and dedication of researchers around the globe. Moreover, as is also pointed out by Hipel *et al.* (2007), there is a great need to develop a solid theoretical foundation to the field of Systems Engineering along with an array of systems tools for handling many types of complex systems of systems problems. As exemplified by the unexpected tsunami of December 26, 2004, which ravaged nations adjoining the Indian Ocean, society may not even be aware of sudden disasters that could take place in the future. Hence, these systems tools must be comprehensive and integrated and be capable of handling vast amounts of information such that key decisions can be made in real time to mitigate the array of complex risks associated with any large-scale disaster.

#### Acknowledgments

The authors would like to sincerely congratulate Professor Norio Okada on the occasion of his 60<sup>th</sup> birthday, and to join in the celebration of his many academic accomplishments and his remarkable career. Hence, they are thankful for being afforded the opportunity to participate in the “International Conference on Vitae Systems – New Paradigm for Systems

Science: Survivability, Vitality and Conviviality in Society”, which was held in the Clock Tower Building at Kyoto University, Kyoto, Japan, on December first and second in 2007. The original version of this paper was presented as a keynote address at this highly successful conference. The authors are especially appreciative of the collegiality and friendship that Professor Okada has shared with them, as with his many students and other colleagues, over the past three decades, and look forward to many more years of cooperation and comradeship. They are also grateful to his colleagues and former students for having so ably organized and carried out such an excellent international conference in his honour. Finally, the authors would like to thank Professor Okada, as well as many other Japanese and international colleagues, for the key roles they have played in educating both Japanese and Canadian students to have a systems perspective in their careers and lives, as demonstrated by the highly successful student exchange programs that Professor Okada helped to establish between Tottori and Kyoto Universities, and the University of Waterloo (Hipel *et al.*, 2003; Fukuyama *et al.*, 2005).

## References

- Al-Mutairi, M.S., Hipel, K.W. and Kamel, M.S. (2008) ‘Fuzzy preferences in conflicts’, *Journal of Systems Science and Systems Engineering*, Vol. 17, No. 3, pp. 257-276.
- Belton, V. and Stewart, T.J. (2002) *Multiple Criteria Decision Analysis: An Integrated Approach*, (Dordrecht: Kluwer).
- Blackett, P.M.S. (1962) *Studies of War*, (Edinburgh: Oliver and Boyd).
- Bryant, J. (2003) *The Six Dilemmas of Collaboration: Inter-organisational Relationships as Drama*, (Chichester: John Wiley & Sons).
- Chen, Y., Hipel, K.W. and Kilgour, D.M. (2007) ‘Multiple criteria sorting using case-based distance models with an application in water resources management’, *IEEE Transactions on Systems, Man, and Cybernetics, Part A: Systems and Humans*, Vol. 37, No. 5, pp. 680-691.
- Chen, Y., Kilgour, D.M. and Hipel, K.W. (2006) ‘Multiple criteria classification with an application in water resources planning’, *Computers and Operations Research*, Vol. 33, No. 11, pp. 3301-3323.
- Chen, Y., Kilgour, D.M. and Hipel, K.W. (2008) ‘Screening in multiple criteria decision analysis’, *Decision Support Systems*, Vol. 45, pp. 278-290.
- Fang, L., Hipel, K.W. and Kilgour, D.M. (1993) *Interactive Decision Making: The Graph Model for Conflict Resolution*, (New York: Wiley).
- Fang, L., Hipel, K.W., Kilgour, D.M. and Peng, X. (2003a) ‘A decision support system for interactive decision making, Part 1: Model formulation’, *IEEE Transactions on Systems, Man, and Cybernetics, Part C: Applications and Reviews*, Vol. 33, No. 1, pp. 42-55.
- Fang, L., Hipel, K.W., Kilgour, D.M. and Peng, X. (2003b) ‘A decision support system for interactive decision making, Part 2: Analysis and output interpretation’, *IEEE Transactions on Systems, Man, and Cybernetics, Part C: Applications and Reviews*, Vol. 33, No. 1, pp. 56-66.
- Fang, L., Kilgour, D.M. and Hipel, K.W. (1997) ‘How penalty affects enforcement of environmental regulations’, *Applied Mathematics and Computation*, Vol. 83, Nos. 2 & 3, pp. 281-301.
- Fraser, N.M. and Hipel, K.W. (1979) ‘Solving complex conflicts’, *IEEE Transactions on Systems, Man, and Cybernetics*, Vol. 9, No. 12, pp. 805-816.
- Fraser, N.M. and Hipel, K.W. (1984) *Conflict Analysis: Models and Resolutions*, (New York: NorthHolland).
- Fukuyama, K., Kilgour, D.M. and Hipel, K.W. (1994) ‘Systematic policy development to ensure compliance to environmental regulations’, *IEEE Transactions on Systems, Man and Cybernetics*, Vol. 24, No. 9, pp. 1289-1305.
- Fukuyama, K., Kilgour, D.M. and Hipel, K.W. (2000) ‘Self-reporting systems for environmental compliance’, *Journal of Water Resources Planning and Management*, Vol. 126, No. 1, pp.3-12.
- Fukuyama, K., Okada, N. and Hipel, K.W. (2005) ‘Internationalization of engineering education through exchange programs’, *Journal of the Japanese Society for Engineering Education*, Vol. 53, No. 2, pp. 36-42.
- Haimes, Y.Y. (2009) *Risk Modeling, Assessment, and Management*, 3rd Edition, (Hoboken, New Jersey: Wiley-Interscience).
- Hammond, J.S., Keeney, R.L. and Raiffa, H. (1999) *Smart Choices: A Practical Guide to Making Better Decisions*, (Boston: Harvard Business School Publishing).
- Hamouda, L., Kilgour, D.M. and Hipel, K.W. (2004) ‘Strength of preference in the graph model for conflict resolution’, *Group Decision and Negotiation*, Vol. 13, pp. 449-462.

- Hamouda, L., Kilgour, D.M. and Hipel, K.W. (2006) 'Strength of preference in graph models for multiple decision-maker conflicts', *Applied Mathematics and Computation*, Vol. 179, pp. 314-327.
- Hatfield, A.J. and Hipel, K.W. (2002) 'Risk and systems theory', *Risk Analysis: An International Journal*, Vol. 22, No. 6, pp. 1043-1057.
- Hipel, K.W. (Ed.) (2009a) *Conflict Resolution, Volume 1*, (Oxford, UK: Eolss Publishers).
- Hipel, K.W. (Ed.) (2009b) *Conflict Resolution, Volume 2*, (Oxford, UK: Eolss Publishers).
- Hipel, K.W. and Ben-Haim, Y. (1999) 'Decision making in an uncertain world: information – gap modeling in water resources management', *IEEE Transactions on Systems, Man and Cybernetics, Part C: Applications and Reviews*, Vol. 29, No. 4, pp. 506-517.
- Hipel, K.W. and Fang, L. (Eds.) (1994) *Effective Environmental Management for Sustainable Development*, (Dordrecht, The Netherlands: Kluwer).
- Hipel, K.W. and Fang, L. (2005) 'Multiple participant decision making in societal and technological systems', in T. Arai, S. Yamamoto, and K. Makino, (Eds.), *Systems and Human Science—For Safety, Security, and Dependability*. Selected Papers of the 1st International Symposium, SSR2003, Osaka, Japan, Published by Elsevier, Amsterdam, The Netherlands, Chapter 1, pp. 3-31, 2005.
- Hipel, K.W., Fang, L. and Heng, M. (2010) 'System of systems approach to policy development for global food security', *Journal of Systems Science and Systems Engineering*, Vol. 19, No. 1, pp. 1-21.
- Hipel, K.W., Fang, L. and Kilgour, D.M. (1993) 'Game theoretic models in engineering decision making', *Journal of Infrastructure Planning and Management, Japan Society of Civil Engineers*, No.470/IV-20, pp.1-16.
- Hipel, K.W. and Fraser, N.M. (1980) 'Metagame analysis of the Garrison conflict', *Water Resources Research*, Vol. 16, No. 4, pp. 629-637.
- Hipel, K.W., Jamshidi, M.M., Tien, J.J., and White III, C.C. (2007) 'The future of systems, man and cybernetics: application domains and research methods', *IEEE Transactions on Systems, Man, and Cybernetics, Part C: Applications and Reviews*, Vol. 37, No. 5, pp. 726-743.
- Hipel, K.W., Kilgour, D.M., and Bashar, M.A. (2011) 'Fuzzy preferences in multiple participant decision making', *Scientia Iranica*, special publication in honour of Professor Lotfi Zadeh, to appear.
- Hipel, K.W., Kilgour, D.M., Fang, L. and Peng, X. (1997) 'The decision support system GMCR II in environmental conflict management', *Applied Mathematics and Computation*, Vol. 83, No. 2/3, pp. 117-152.
- Hipel, K.W., Kilgour, D.M., Fang, L. and Peng, X. (2001) 'Strategic decision support for the services industry', *IEEE Transactions on Engineering Management*, Vol. 48, No. 3, pp. 358-369.
- Hipel, K.W., Kilgour, D.M., Rajabi, S., and Chen, Y. (2008a) 'Chapter 27 - Operations Research and Refinement of Courses of Action', In *Handbook of Systems Engineering and Management*, edited by A.P. Sage and W.B. Rouse, Second edition, (New York: Wiley).
- Hipel, K.W. and McLeod, A.I. (1994) *Time Series Modeling of Water Resources and Environmental Systems*, (Amsterdam: Elsevier).
- Hipel, K.W., Obeidi, A., Fang, L. and Kilgour, D.M. (2008b), 'Adaptive systems thinking in integrated water resources management with insights into conflicts over water exports', *INFOR*, Vol. 46, No. 1, pp. 51-69.
- Hipel, K.W., Obeidi, A., Fang, L. and Kilgour, D.M. (2009), 'Sustainable environmental management from a system of systems perspective', In *System of Systems Engineering: Innovations for the 21st Century*, edited by M. Jamshidi, Wiley, New York, Chapter 18, pp. 443-481.
- Hipel, K.W., Okada, N., and Fukuyama, K. (2003) 'The internationalization of engineering education: a tale of two countries', *IEEE Transactions on Systems, Man and Cybernetics, Part C: Applications and Reviews*, Vol. 33, No. 1, pp. 137-148.
- Hobbs, B.F. and Meier, P. (2000) *Energy Decisions and the Environment: A Guide to the Use of Multicriteria Methods*, (Massachusetts: Kluwer).
- Howard, N. (1971) *Paradoxes of Rationality: Theory of Metagames and Political Behaviour*, (Cambridge, Massachusetts: MIT Press).
- Howard, N. (1999) *Confrontation Analysis: How to Win Operations Other Than War*, (Pentagon, Washington, DC: CCRP Publications).
- Inohara, T. and Hipel, K.W. (2008a) 'Coalition analysis in the graph model for conflict resolution', *Systems Engineering*, Vol. 11, No. 4, pp. 343-359.
- Inohara, T. and Hipel, K.W. (2008b) 'Interrelationships among noncooperative and coalition stability concepts', *Journal of Systems Science and Systems Engineering*, Vol. 17, No. 1, pp. 1-29.

- Inohara, T., Hipel, K.W., and Walker, S. (2007) 'Conflict analysis approaches for investigating attitudes and misperceptions in the war of 1812', *Journal of Systems Science and Systems Engineering*, Vol. 16, No. 2, pp. 181-201.
- Kilgour, D.M., Fang, L. and Hipel, K.W. (1992) 'Game-theoretic analyses of enforcement of environmental laws and regulations', *Water Resources Bulletin*, Vol. 28, No. 1, pp. 141-153.
- Kilgour, D.M., Hipel, K.W. and Fang, L. (1987) 'The graph model for conflicts', *Automatica*, Vol. 23, No.1, pp. 41-55.
- Kilgour, D. M., Hipel, K.W., Fang, L. and Peng, X. (2001) 'Coalition analysis in group decision support', *Group Decision and Negotiation*, Vol. 10, No. 2, pp. 159-175.
- Kilgour, D.M., Okada, N. and Nishikori, A. (1988) 'Load control regulation of water pollution: an analysis using game theory', *Journal of Environmental Management*, Vol. 27, pp. 179-194.
- Li, K.W., Hipel, K.W., Kilgour, D.M. and Fang, L. (2004a) 'Preference uncertainty in the graph model for conflict resolution', *IEEE Transactions on Systems, Man, and Cybernetics, Part A: Systems and Humans*, Vol. 34, No. 4, pp. 507-520.
- Li, K.W., Hipel, K.W., Kilgour, D.M., and Noakes, D.J. (2005a) 'Integrating uncertain preferences into status quo analysis with application to an environmental conflict', *Group Decision and Negotiation*, Vol. 14, No. 6, pp. 461-479.
- Li, K.W., Kilgour, D.M. and Hipel, K.W. (2004b) 'Status quo analysis of the Flathead River conflict', *Water Resources Research*, Vol. 40, No. 5, W05S03, doi:10.1029/2003WR002596 (9 pages).
- Li, K.W., Kilgour, D.M. and Hipel, K.W. (2005b) 'Status quo analysis in the graph model for conflict resolution', *Journal of the Operational Research Society*, Vol. 56, No. 6, pp. 699-707.
- Maier, M. (1998) 'Architecting principles for systems-of-systems', *Systems Engineering*, Vol. 1, No. 4 , pp. 267-284.
- Nandalal, K.W.D. and Hipel, K.W. (2007) 'Strategic decision support for resolving conflict over water sharing among countries along the Syr Darya River in the Aral Sea Basin', *Journal of Water Resources Planning and Management*, Vol. 133, No. 4, pp. 289-299.
- Obeidi, A., Hipel, K.W. and Kilgour, D.M. (2005) 'The role of emotions in envisioning outcomes in conflict analysis', *Group Decision and Negotiation*, Vol. 14, No. 6, pp. 481-500.
- Obeidi, A., Hipel, K.W. and Kilgour, D.M. (2006) 'Turbulence in Miramichi Bay: the Burnt Church conflict over native fishing rights', *Journal of the American Water Resources Association*, Vol. 42, No. 12, pp. 1629-1645.
- Obeidi, A., Kilgour, D.M., and Hipel, K.W.(2009a) 'Perceptual stability analysis of a graph model system', *IEEE Transactions on Systems, Man, and Cybernetics, Part A, Systems and Humans*, Vol. 39, No. 5, pp. 993-1006.
- Obeidi, A., Kilgour, D.M., and Hipel, K.W. (2009b) 'Perceptual graph model systems', *Group Decision and Negotiation*, Vol. 18, No. 3, pp. 261-277.
- Okada, N. (2002) 'Developing an indicator of a community's disaster risk awareness', in: *Risk, Reliability, Uncertainty, and Robustness of Water Resources Systems*, eds. J. Bogardi and Z. Kundzewicz, pp. 62-69, Cambridge University Press, Cambridge, United Kingdom.
- Okada, N., Fang, L. and Hipel, K.W. (2006) 'Perspectives in participatory infrastructure management', *Journal of Infrastructure Planning and Management, Japan Society of Civil Engineers*, Vol. 62, No. 3, pp. 417-429.
- Okada, N., Hipel, K.W., Fraser N.M. and Fukushima, M. (1988) *Konfurikuto No Suuri (Mathematical Modelling of Conflict Resolution)* (in Japanese), (Kyoto, Japan: Gendai Sugakusha (Publisher)).
- Okada, N., Hipel, K.W. and Oka, Y. (1985) 'Hypergame analysis of the Lake Biwa Conflict', *Water Resources Research*, Vol.21, No. 7, pp. 917-926.
- Rajabi, S., Hipel, K.W. and Kilgour, D.M. (1999) 'Water supply planning under interdependence of actions: theory and application', *Water Resources Research*, Vol. 35, No. 7, pp. 2225-2235.
- Rajabi, S., Kilgour, D.M. and Hipel, K.W. (1998) 'Modelling action - interdependence in multiple criteria decision making', *European Journal of Operational Research*, Vol. 110, No. 3, pp. 490-508.
- Sage, A.P. (1992) *Systems Engineering*, (New York: Wiley).
- Sage, A.P. and Biemer, S.M. (2007) 'Processes for system family architecting design, and integration', *IEEE Systems Journal*, Vol. 1, No. 1, pp. 5-16.
- Sage, A.P. and Cuppan, C.D. (2001) 'On the systems engineering and management of systems of systems and federations of systems', *Information Knowledge Systems Management*, Vol. 2, No. 4, pp. 325-345.
- Sage, A.P. and Rouse, W.B. (2008) *Handbook of Systems Engineering and Management*, second edition, (New York: Wiley).

- Von Neumann, J. and Morgenstern, O. (1953) *Theory of Games and Economic Behavior*, third edition, (Princeton, NJ: Princeton University Press).
- Waddington, C.H. (1973) *OR in World War 2*, (London: Elek Science).
- Walker, S., Hipel, K.W. and Inohara, T. (2009) 'Strategic decision making for improved environmental security: Coalitions and attitudes in the graph model for conflict resolution', *Journal of Systems Science and Systems Engineering*, Vol. 18, No. 4, pp. 461-476.
- Wang, L., Fang, L. and Hipel, K.W. (2007a) 'Mathematical programming approaches for modeling water rights allocation', *Journal of Water Resources Planning and Management*, Vol. 133, No. 1, pp. 50-59.
- Wang, L., Fang, L. and Hipel, K.W. (2007b) 'On achieving fairness in the allocation of scarce resources: Measurable principles and multiple objective optimization approaches', *IEEE Systems Journal*, Vol. 1, No.1, pp. 17-28.
- Wang, L., Fang, L. and Hipel, K.W. (2008a) 'Basin-wide cooperative water resources allocation', *European Journal of Operational Research*, Vol. 190. pp. 798-817.
- Wang, L., Fang, L., and Hipel, K.W. (2008b) 'Integrated hydrologic-economic modeling of coalitions of stakeholders for water allocation in the South Saskatchewan River Basin', *Journal of Hydrologic Engineering*, Vol. 13, No. 9, pp. 781-792.
- Waterloo Regional Council (2000) 'Waterloo's long term water strategy', Waterloo Regional Council Report, E-00-027.1, Waterloo, Ontario, Canada.
- Xu, H., Hipel, K.W., and Kilgour, D.M. (2009a) 'Matrix representation of solution concepts in multiple decision maker graph models', *IEEE Transactions on Systems, Man, and Cybernetics, Part A: Systems and Humans*, Vol. 39, No. 1, pp. 96-108.
- Xu, H., Hipel, K.W. and Kilgour, D.M. (2009b) 'Multiple levels of preference in interactive strategic decisions', *Discrete Applied Mathematics*, Vol. 57, pp. 3300-3313.
- Xu, H, Li, K.W., Kilgour, D.M., and Hipel, K.W. (2009c) 'A matrix-based approach to searching colored paths in a weighted colored multidigraph', *Applied Mathematics and Computation*, Vol. 215, No. 1, pp. 353-366.
- Zeng, D-Z., Fang, L., Hipel, K.W., and Kilgour, D.M. (2007) 'Policy equilibrium and generalized metarationalities for multiple decision-maker conflicts', *IEEE Transactions on Systems, Man, and Cybernetics, Part A: Systems and Humans*, Vol. 37, No. 4, pp. 456-463.